

REAL CEDAR CEDAR COOLER STAND

DESIGN: REAL CEDAR ORIGINAL

This stylish Real Cedar mobile deck bar is the perfect beverage cooler for cottagers and city dwellers alike. For urban outdoor living spaces where space is an issue, this compact drinking station can fit just about anywhere and still leave plenty of room for seating and the all-important BBQ. And for vast rural spaces, it keeps thirsty guests from having to run back and forth to the cabin kitchen every time they want a top-up.

Plus, it's made from beautiful Western Red Cedar, which is easy to work with as well as naturally resistant to rot, decay and insects. So this portable party is not only fun to build, it's going to last you a long time. Cheers to that and happy summer!

In terms of WRC grades choose Select Knotty for a more rustic look. For a more polished, contemporary look, specify clear grades of WRC. And when it comes to specifying sizes, we recommend asking your local Real Cedar retailer if they have any short lengths in stock. Using short lengths means less cutting, less waste and more savings for you.

WHAT YOU'LL NEED

Part #	Description	FINISHED SIZE			Nominal Sizes	Material	Qty.
		Thickness	Width	Length			
Hardware							
O	1/2" Piano Hinge			20 1/2"		Stainless Steel	1
P	Flat Head Screws #6			3/4"		Stainless Steel	20
Q	Screws #8			3"		Stainless Steel	30
R	Screws #8			3 1/2"		Stainless Steel	4
S	Finishing Nails 16 Gauge			1 1/4"		Stainless Steel	250
	Cooler - specified as maximum dimensions for opening						
Parts							
A	Legs	3"	3"	28 1/2"	4" x 4" x 3"	WR Cedar Smooth	4
B1	Sides	3/4"	2 1/2"	17"	1" x 3" x 2'	T&G WR Cedar	2
B2	Sides	3/4"	3"	17"	1" x 3" x 2'	T&G WR Cedar	6
B3	Sides	3/4"	2 5/8"	17"	1" x 3" x 2'	T&G WR Cedar	2
C1	Back	3/4"	2 1/2"	38 1/2"	1" x 3" x 4'	T&G WR Cedar	1
C2	Back	3/4"	3"	38 1/2"	1" x 3" x 4'	T&G WR Cedar	3
C3	Back	3/4"	2 5/8"	38 1/2"	1" x 3" x 4'	T&G WR Cedar	1
D1	Front	3/4"	2 1/2"	38 1/2"	1" x 3" x 4'	T&G WR Cedar	1
D2	Front	3/4"	3"	28 1/2"	1" x 3" x 3'	T&G WR Cedar	3
D3	Front	3/4"	2 5/8"	28 1/2"	1" x 3" x 3'	T&G WR Cedar	1
E1	Frame	1 1/2"	2 1/4"	38 1/2"	2" x 3" x 4'	WR Cedar Smooth	2
E2	Frame	1 1/2"	2 1/4"	12 1/2"	2" x 3" x 2'	WR Cedar Smooth	4
F	Support	1 1/2"	4 1/2"	11 7/8"	2" x 6" x 1'	WR Cedar Smooth	2
G	Support	1 1/2"	1 1/2"	4 1/2"	2" x 2" x 1'	WR Cedar Smooth	2
H	Base	1 1/2"	4 1/2"	12 1/2"	2" x 6" x 2'	WR Cedar Smooth	1
I1	Inside Wall	3/4"	3"	15 1/2"	1" x 3" x 2'	T&G WR Cedar	6
I2	Inside Wall	3/4"	2 11/16"	15 1/2"	1" x 3" x 2'	T&G WR Cedar	2
J1	Inside Base	3/4"	2 1/4"	10"	1" x 3" x 1'	WR Cedar Smooth	1
J2	Inside Base	3/4"	3"	10"	1" x 3" x 1'	WR Cedar Smooth	4
J3	Inside Base	3/4"	2"	10"	1" x 3" x 1'	WR Cedar Smooth	1
K	Back Bracing	1"	1 1/2"	36"	2" x 2" x 3'	WR Cedar Smooth	1
L	Cooler Support	1"	1"	22 3/4"	1" x 1" x 2'	WR Cedar Smooth	2
M+N	Top	1 1/2"	5 1/2"	43"	2" x 6" x 4'	WR Cedar Smooth	4

DISCLAIMER: These projects require ripping standard size materials down to the net sizes shown.

NOTE: Real Cedar is not responsible for any personal injury or property damage sustained in connection to these guidelines.

FASTENER PRO TIPS

1. Where gluing is required, only apply a polyurethane construction adhesive specially formulated for outdoor applications. Using a scrap of wood, spread a thin even layer of glue like butter on toast. Avoid applying excessive amounts and keep glue at least 1/2" away from exterior edges of joint to avoid unappealing bleed out. Press pieces in place briefly, then pull them apart for a second before pressing firmly back in place (this helps activate the glue so it will set faster). Always use clamps to keep pieces in position while driving in screws because until the glue dries, pieces are at risk of slipping.
2. For all outdoor work, you should use corrosion-resistant stainless steel or hot-dipped galvanized nails. Other fasteners and hardware such as bolts, screws and hinges should also be made from similar corrosion resistant materials.

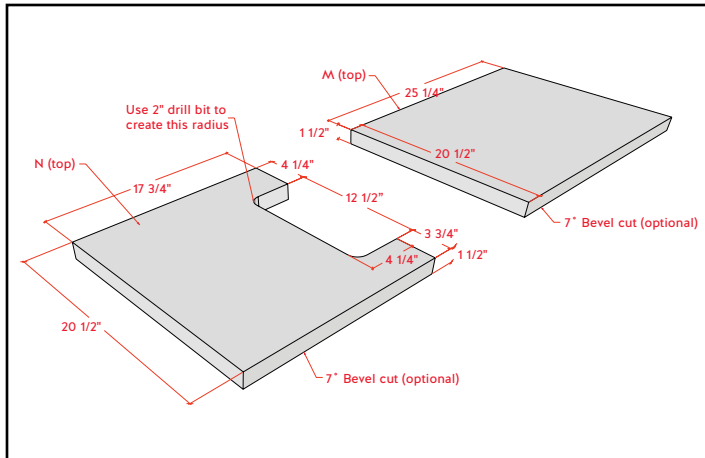

STEP 1 - Build Lids

With a table saw or a circular saw with guide cut off the curved eased edges from (M) pieces (approx. 3/16 strip). Laminate (M) pieces together as one big slab, using clamps and glue. Let dry for 24 hours. With a circular saw and jigsaw cut laminated as described in diagram.

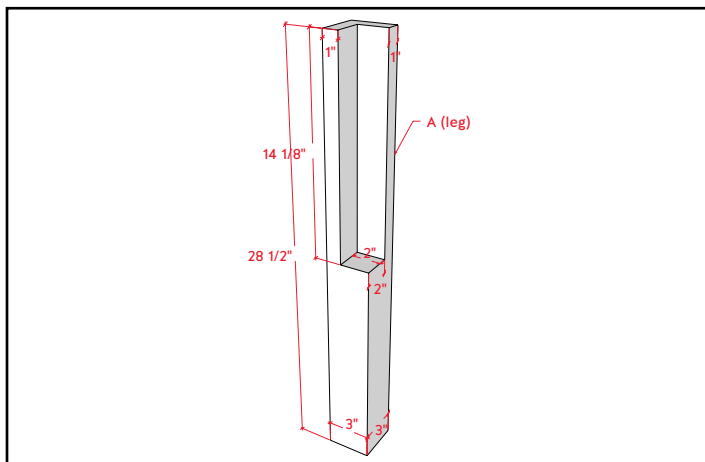

STEP 2 - Prepare Legs & Sides

Using a table saw, rip legs to a finished size of 3" x 3". Cut and notch out the four (A) legs.

Cut (B, C, D, I, J) T&G pieces to their finish length.

Noting finished width in the parts list, with a saw cut off the "tongue" bottom edges of B1, C1, D1, I1 and J1 (Note: D1 will require an additional cut (see step 4)) and the top "groove" edges of B3, C3, D3, I3 and J3 for a flat finished edge.

Using a brad nail gun, install T&G siding (B1, B2, B3) using 1 1/4" nails and glue. Nail from the back side so that the nail heads are hidden.

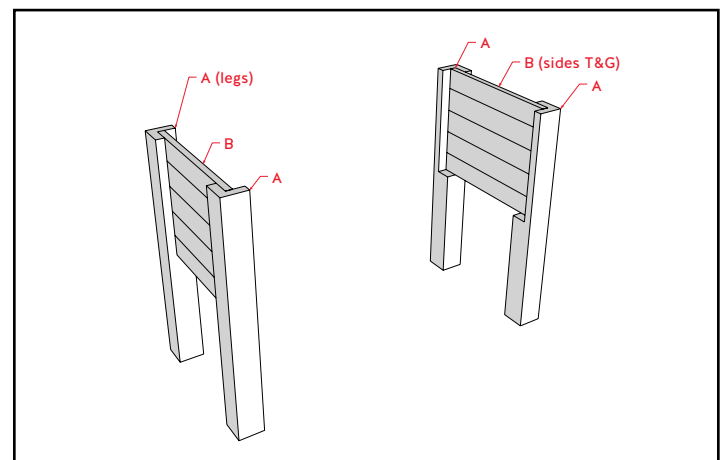
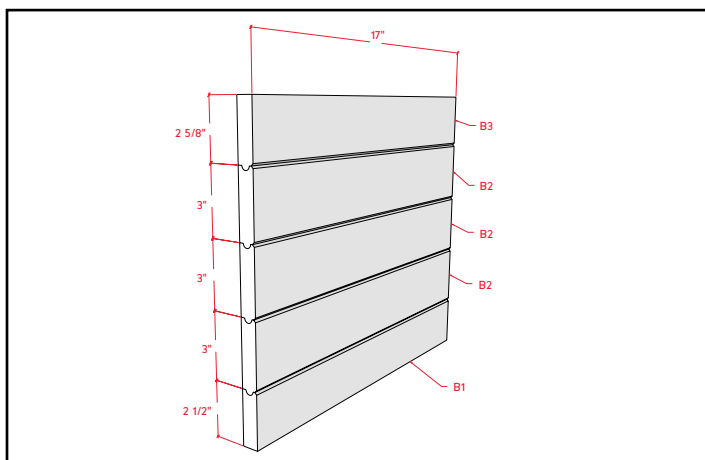

NOTE: Real Cedar is not responsible for any personal injury or property damage sustained in connection to these guidelines.

STEP 3 - Build Bottom Support

Connect two long (E1) frames by attaching four (E2) supports, using 3" screws and glue.

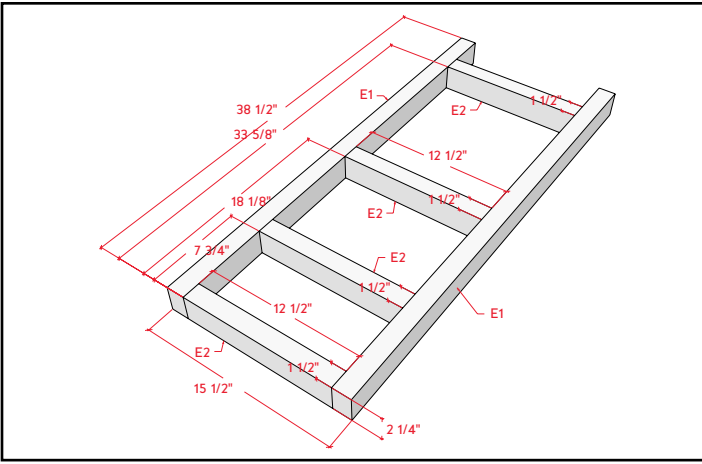

STEP 4 - Complete Exterior Frame

Connect both frame sides with (D1) front and (C) back T&G, using finish nails and glue. Then install bottom frame (E).

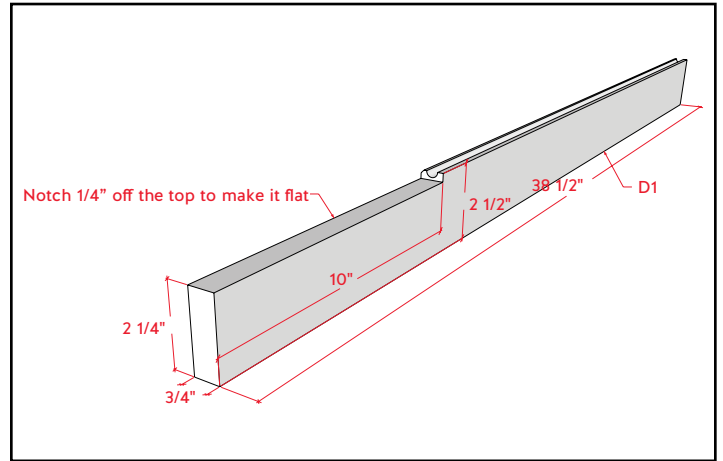
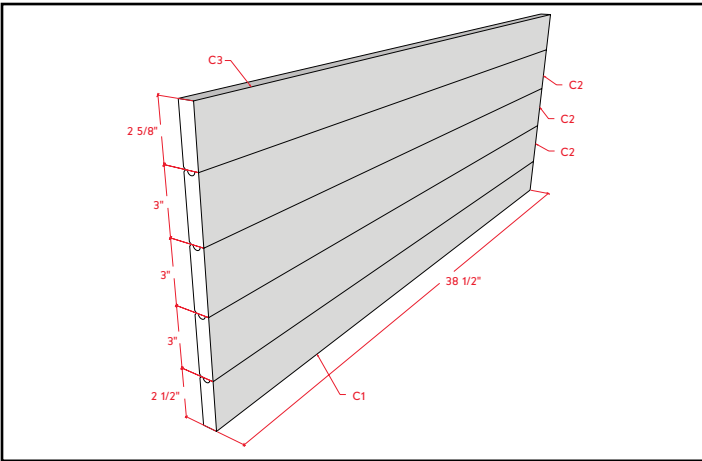
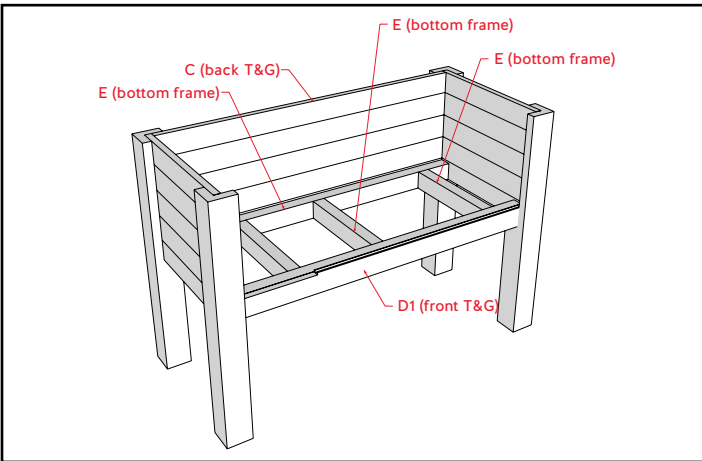

STEP 5 - Install Interior Supports

Using screws, attach (G) supports to (F) supports.

Install one (D2) on top of (D1), before installing (F) front support plumb with outer edge of (D2), and align (F) back support likewise.

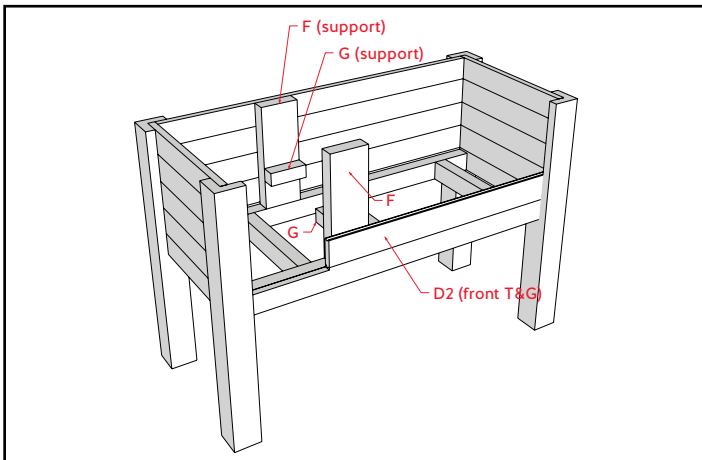
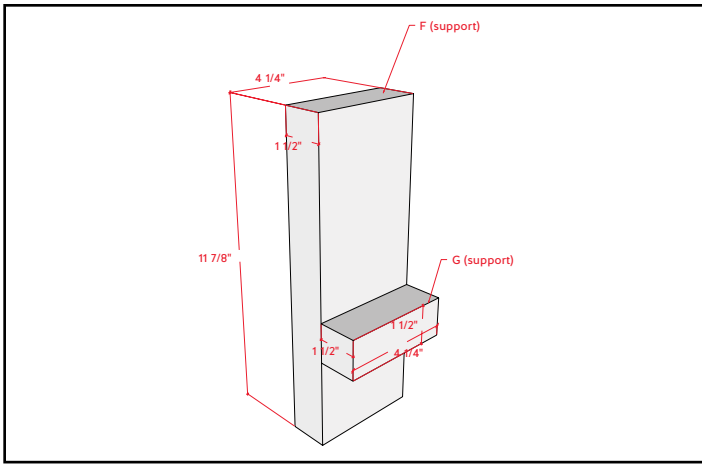

STEP 6 - Add Remaining Front

Install remaining (D2) & (D3) T&G, using finish nails. Place removable (H) base on (G) supports.

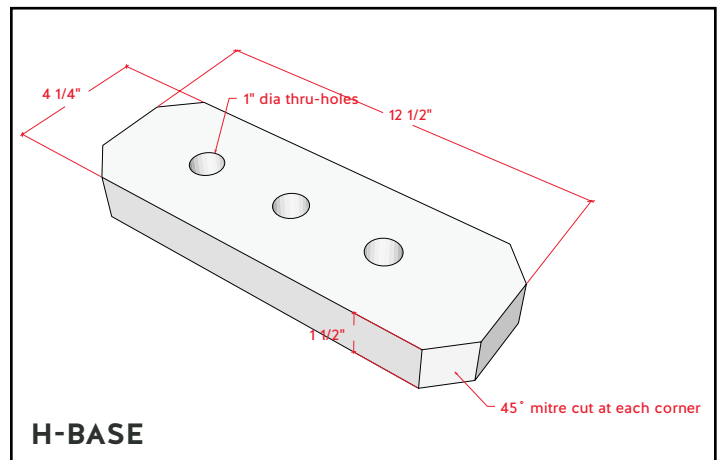
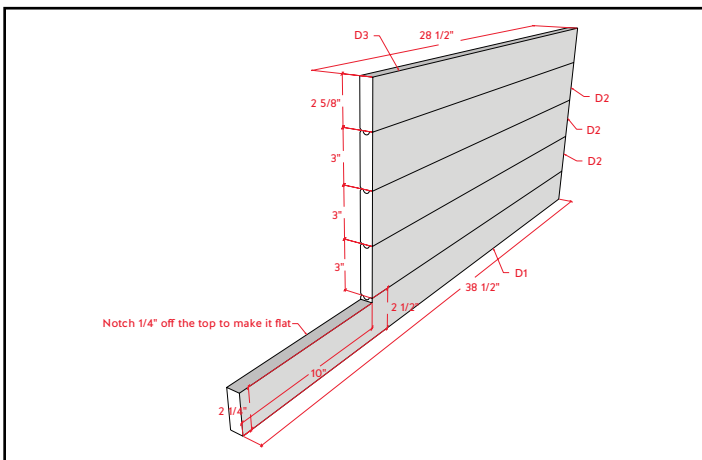
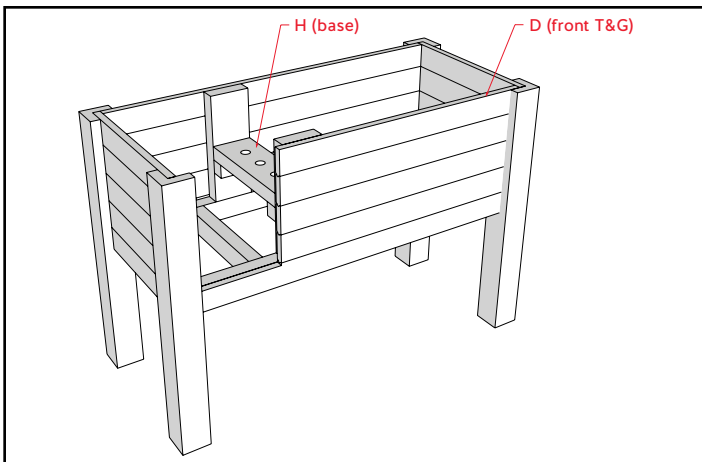

H-BASE

NOTE: Real Cedar is not responsible for any personal injury or property damage sustained in connection to these guidelines.

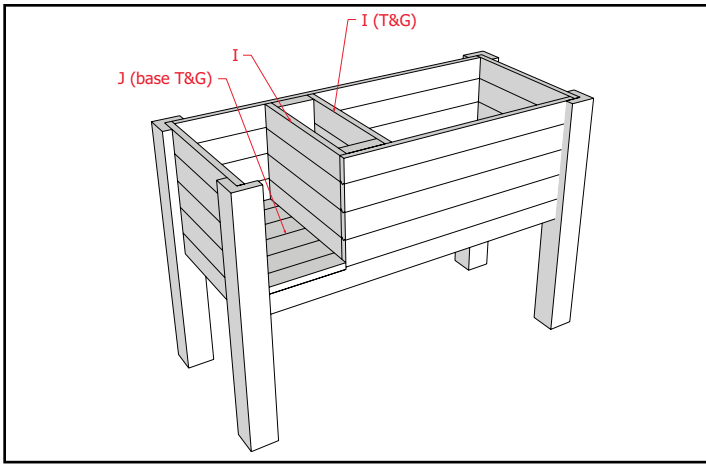

STEP 7 - Install Interior Wood

Install (J) base and (I) interior walls on either side of (F) supports, using finish nails and glue.

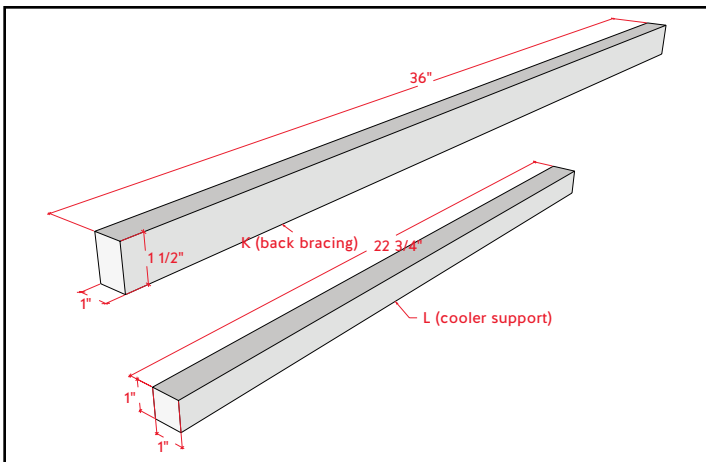
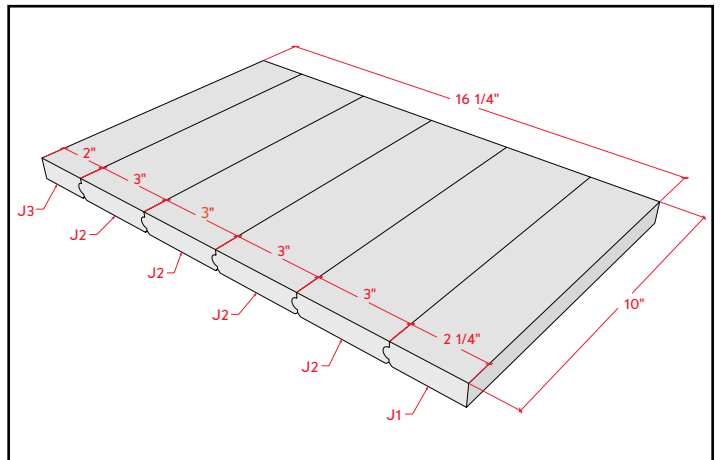
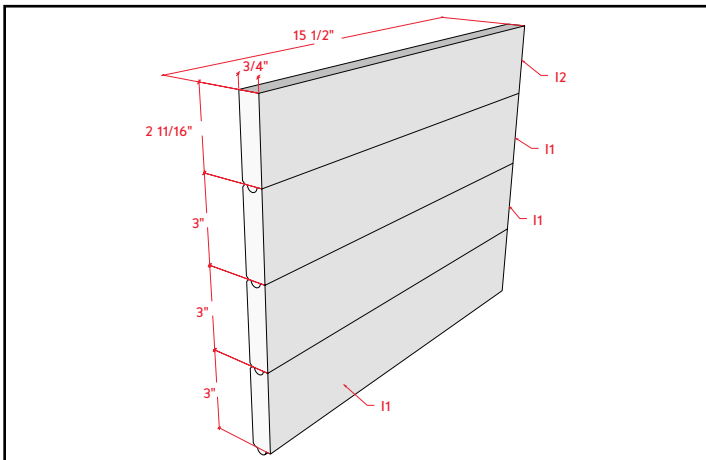

STEP 8 - Add Cooler Support

Attach (K) cooler back brace to exterior of (C) T&G, using finish nails and glue. Then install two (L) cooler spacers to interior of (C) T&G.

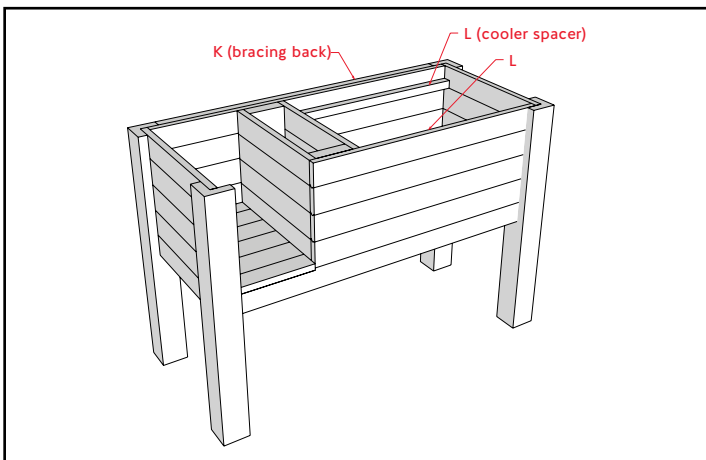

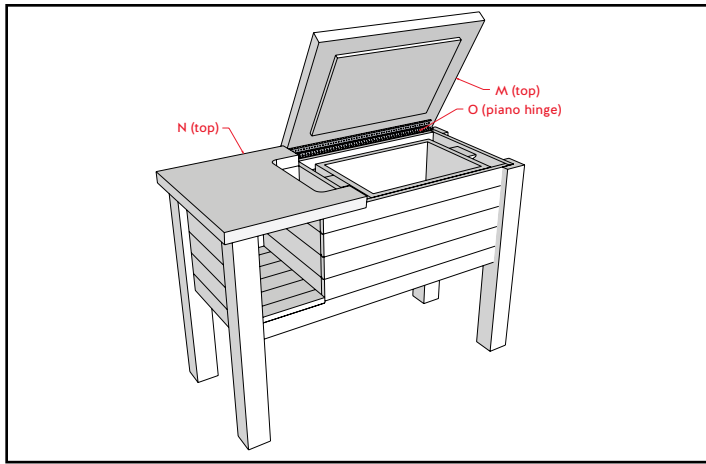

STEP 9 - Attach Tops

True up and sand the fully dried (M) & (N) slab. Shape (N) as per diagram and permanently attach to bar, using finish nails and glue. Secure (M) half to bar using (O) piano hinge and (P) screws.

STEP 10 - Install Cooler Lid

Drive the (R) screws that will eventually hold the lid of the cooler to the top of the bar through the lid. Place the lid on the cooler. Now gently lower the bar top so that the screws protruding from the lid will leave marks. These marks will tell you exactly where you should screw the lid on.