

PRIVACY NOOK

DESIGN: REAL CEDAR ORIGINAL

Create your own backyard getaway with this beautiful Privacy Garden Nook. This modern design is perfect for urban decks, where space is limited. But it's also great for defining space in larger outdoor living areas. And because it's made of durable, long-lasting Western Red Cedar, this stunning structure will be your favorite summer hangout for decades to come. That's because Real Cedar is naturally resistant to rot, decay and insects, making it the ideal building material for all your outdoor projects.

In terms of WRC grades, choose Architect Knotty for a more rustic look and Architect Clear for a polished contemporary look. And when it comes to specifying sizes, we recommend asking your local Real Cedar retailer if they have any short lengths in stock. Using short lengths means less cutting, less waste and more savings for you.

For more fast facts on building with Real Cedar, download our free DIY app - available on the Apple App Store for iOS and at GooglePlay for Android.

Disclaimer: These projects require ripping standard size materials down to the net sizes shown.

WHAT YOU'LL NEED

Part #	Description	FINISHED SIZE			Nominal Sizes	Material	Qty
		Thickness	Width	Length			
Hardware							
S	Screws #8			2-3/4"		Stainless Steel	150
T	Finishing Nails 16 Gauge			2"		Stainless Steel	800 - 1000
Parts							
A	Back Legs	1-1/2"	3-1/2"	78-7/8"	2x4x7'	WR Cedar Smooth	2
B	Vertical Leg Support	1-3/4"	1-1/2"	75-3/8"	2x4x7'	WR Cedar Smooth	2
C	Back Seat Support	1-1/2"	1-1/2"	12-5/8"	2x2x2'	WR Cedar Smooth	2
D	Front Seat Support	1-1/2"	3"	17"	2x4x2'	WR Cedar Smooth	2
E	Front Leg	1-1/2"	5-1/2"	12-5/8"	2x6x2'	WR Cedar Smooth	2
F1	Seat Frame	1-1/2"	4-3/4"	79"	2x6x7'	WR Cedar Smooth	2
F2	Seat Frame	1-1/2"	4-3/4"	19-5/8"	2x6x2'	WR Cedar Smooth	6
G	Front Post	1-1/2"	1-1/2"	75-3/8"	2x2x7'	WR Cedar Smooth	2
H1	Roof Frame	1-1/2"	3-1/2"	82"	2x4x7'	WR Cedar Smooth	1
H2	Roof Frame	1-1/2"	3-1/2"	79"	2x4x7'	WR Cedar Smooth	1
H3	Roof Rafter Ends	1-1/2"	3-1/2"	24-1/4"	2x4x3'	WR Cedar Smooth	2
H4	Roof Rafter	1-1/2"	2-5/8"	21-1/4"	2x4x2'	WR Cedar Smooth	4
I	Rear Post	1-1/2"	1-1/2"	66-1/4"	2x2x6'	WR Cedar Smooth	4
J	Back Slats	3/4"	2-1/2"	78-7/8"	1x3x7'	WR Cedar Smooth	19
K	Seat Slats	3/4"	2-1/2"	78-7/8"	1x3x7'	WR Cedar Smooth	7
L	Side Slats	3/4"	2-1/2"	16-3/8"	1x3x2'	WR Cedar Smooth	38
M	Roof Slats	3/4"	2-1/2"	82"	1x3x7'	WR Cedar Smooth	5
N	Seat Front Trim	1-1/2"	5-1/2"	82"	2x6x7'	WR Cedar Smooth	1
O	Seat Side Trim	1-1/2"	5-1/2"	7"	2x6x1'	WR Cedar Smooth	2
P	Vertical Front Trim	3/4"	2-3/8"	57-1/4"	1x3x5'	WR Cedar Smooth	2
Q	Roof Front Trim	3/4"	3-3/8"	83-1/2"	1x4x7'	WR Cedar Smooth	1
R	Roof Side Trim	3/4"	3-3/8"	26-1/2"	1x4x3'	WR Cedar Smooth	2

FASTENER PRO TIPS

1. Where gluing is required, only apply a polyurethane construction adhesive specially formulated for outdoor applications. Using a scrap of wood, spread a thin even layer of glue like butter on toast. Avoid applying excessive amounts and keep glue at least 1/2" away from exterior edges of joint to avoid unappealing bleed out. Press pieces in place briefly, then pull them apart for a second before pressing firmly back in place (this helps activate the glue so it will set faster). Always use clamps to keep pieces in position while driving in screws because until the glue dries, pieces are at risk of slipping.
2. For all outdoor work, you should use corrosion-resistant stainless steel or hot-dipped galvanized nails. Other fasteners and hardware such as bolts, screws and hinges should also be made from similar corrosion resistant materials.

NOTE: Real Cedar is not responsible for any personal injury or property damage sustained in connection to these guidelines.

STEP 1 - Build Seat Frame

Make a rectangle by attaching two (F1) seat frames with two (F2) seat frames. Then install remaining (F2) seat frames inside, using glue and (S) screws.

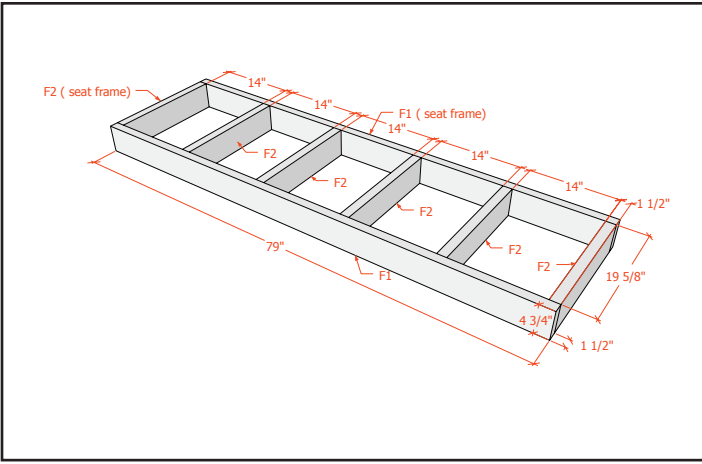

STEP 2 - Build Legs

Using glue and (S) screws, attach (A) back leg with (B) vertical support and then install (C) back seat support to inside corner. Attach (D) front leg support to (E) front leg.

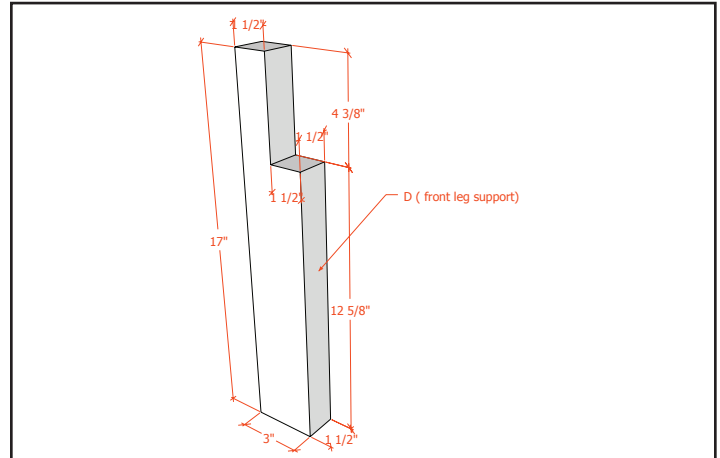
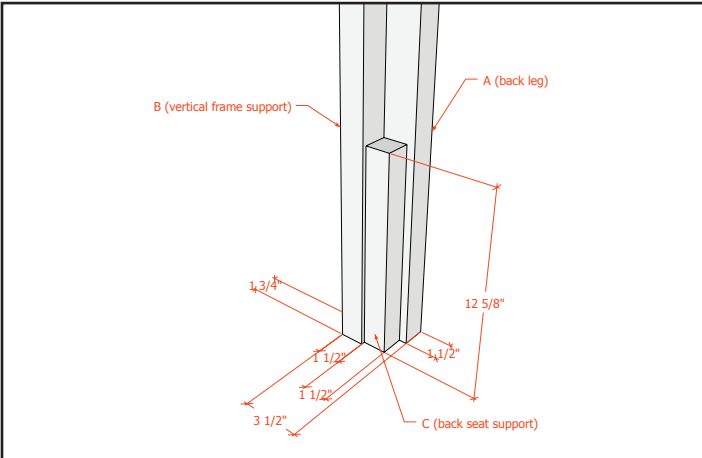
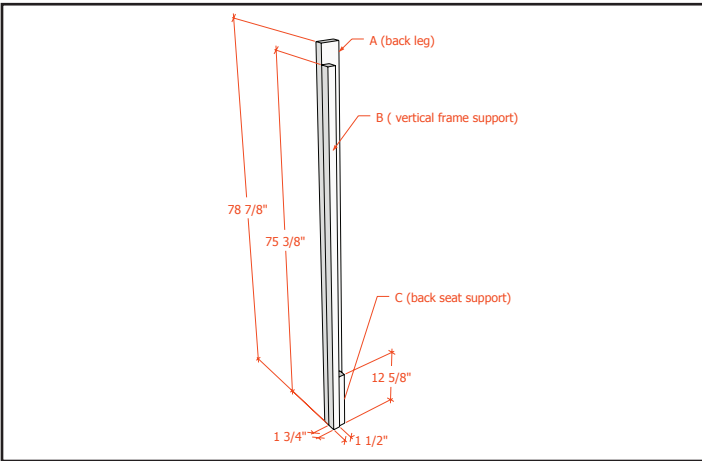

STEP 3 - Install Legs

Attach front legs inside frame and back legs to outer back corners of frame, using glue and (S) screws.

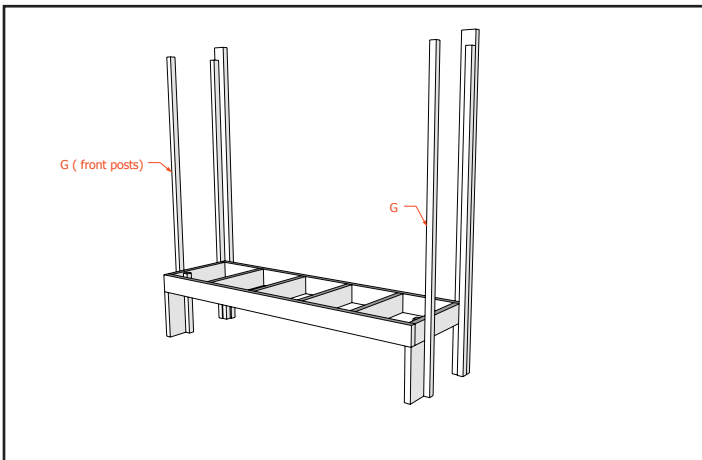
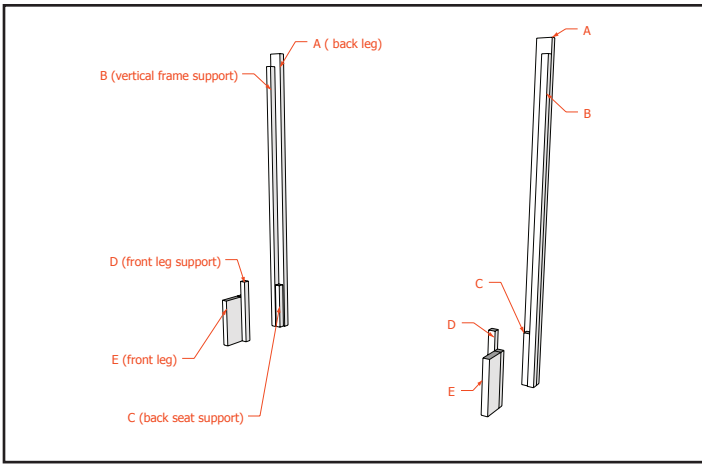

STEP 4 - Build Roof Frame

Make an exterior rectangle by attaching two (H1) roof frames with two (H3) roof frames. Then install remaining (H4) roof frames inside, using glue and (S) screws.

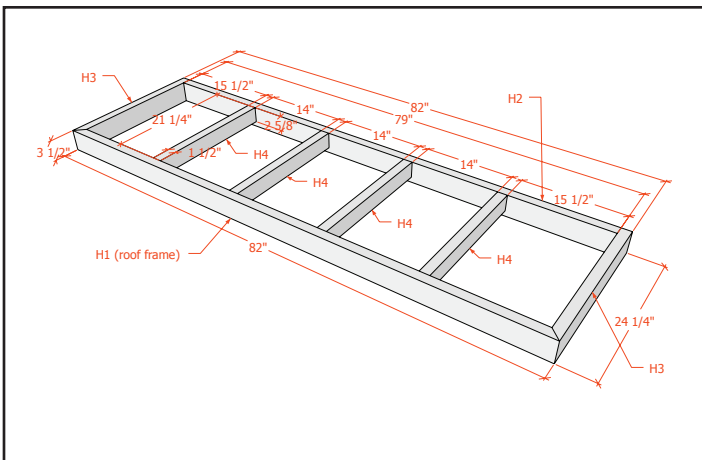

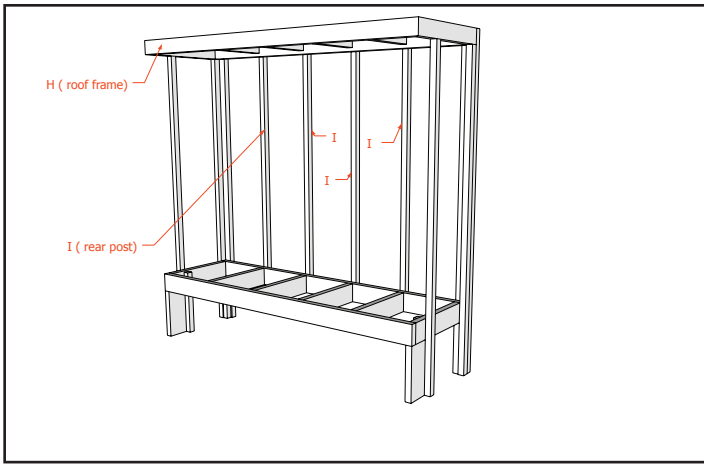

STEP 5 - Install Roof Frame

Using glue and (S) screws, attach (I) posts so that they line up with four interior (F2) seat frames. Then attach roof frame using (S) screws.

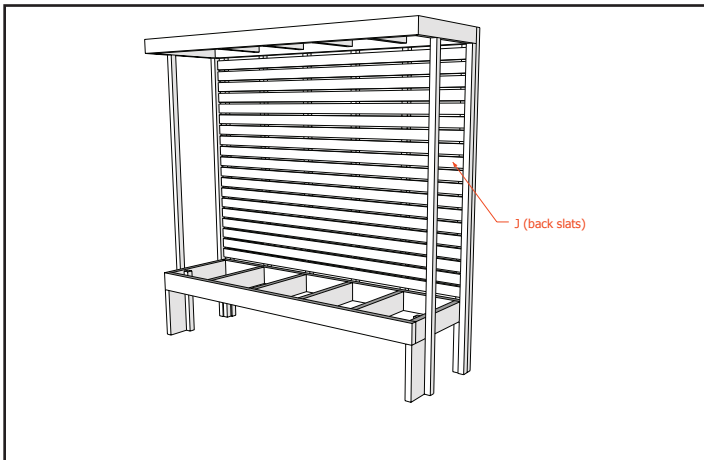

STEP 6 - Install Rear Slats

Attach (J) slats, using glue and (T) finishing nails.

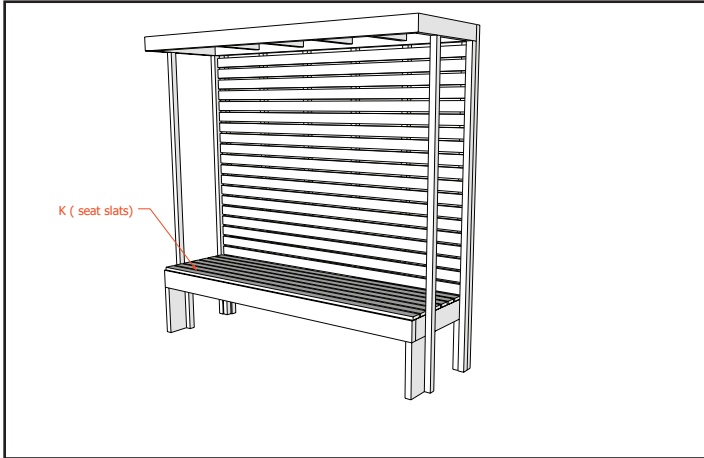

STEP 7 - Add Seating

Install (K) seating, using glue and (T) finishing nails.

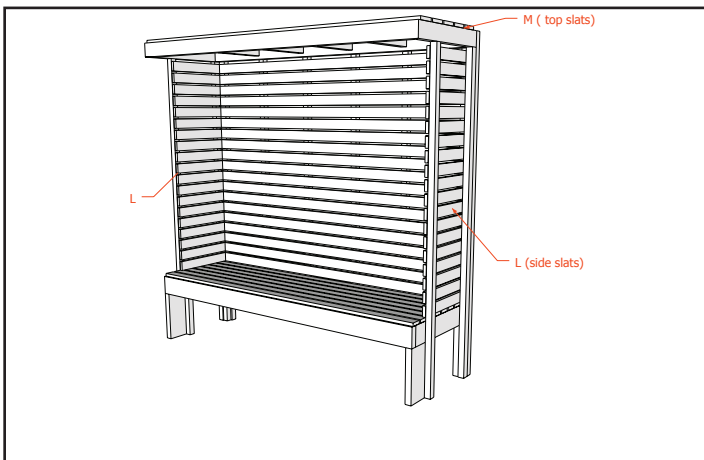

STEP 8 - Add Roof & Side Slats

Install (M) roof slats and (L) side slats, using glue and (T) finishing nails.

STEP 9 – Add Trim

Install (O) side trim & (P) front trim directly to the seat, and add (Q) front trim and (R) directly to the roof, using glue and (T) finishing nails.

